



**ROBOTNG LABS**  
THE NEXT GENERATION  
**ROBOTNG.CA**

**HAUNTED HEXLAB™**

**CRAFT + CODE**

With Tolson Winters, Ben Beck  
and RoboBuddy as: ????

*Everyone Is Welcome Here!*





HAUNTED HEXLAB™  
PART 1:  
CIRCUITS + CODE



# HEXLINK + ROBOBUDDY

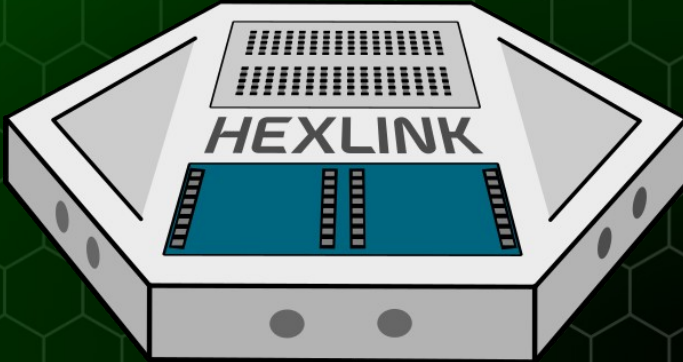

- WeMos D1 mini microcontroller and protoboard on a 3d-printed hexagonal base.
- Edge magnets connect to robotics activity kits from **ROBOTNG LABS**.
- Code in **Python** using the **Thonny IDE**.
- No Soldering required!

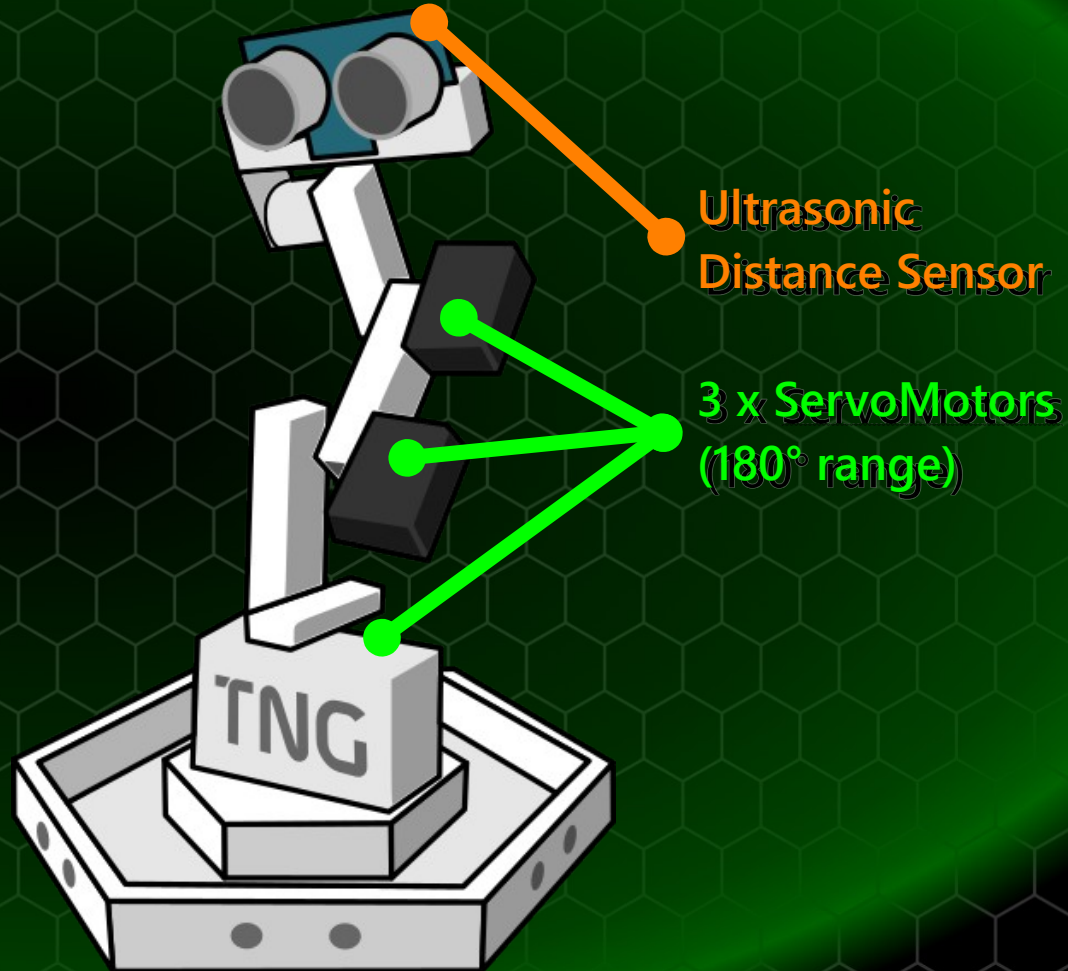



# PROTOBOARD CIRCUITS

Electric Potential:  $V$  (Volt)

Current:  $I$  (Ampere)

Resistance:  $R$  (Ohm)

Ohm's Law:

$$V = IR$$

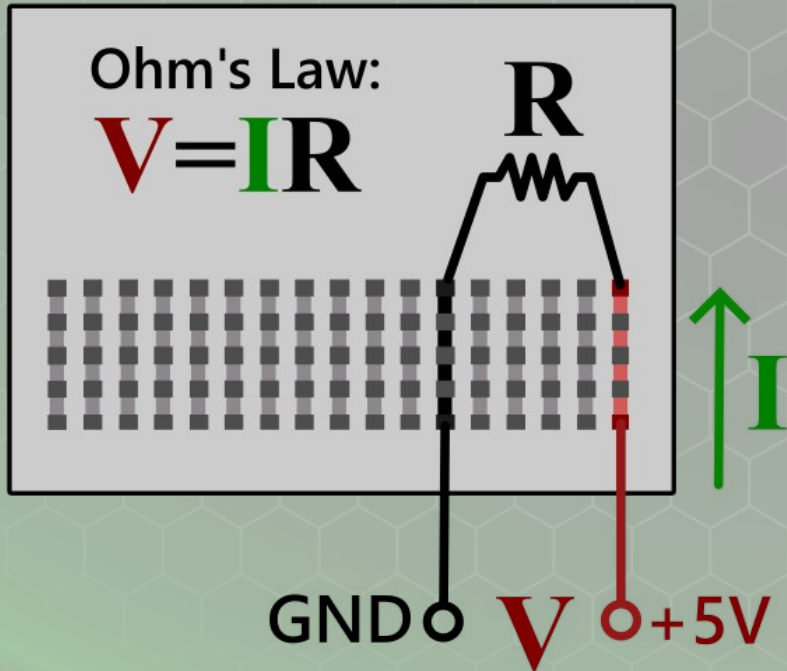

**A Protoboard is Integrated into HEXLINK™!**

- For Making Temporary Circuits
- "Rails" Link Pins as Shown
- Pins May Bend or Break
- Mind Your Fingers!
- Avoid "**Short Circuits**"

# ROBOBUDDY WIRING DIAGRAM (OF DOOM)

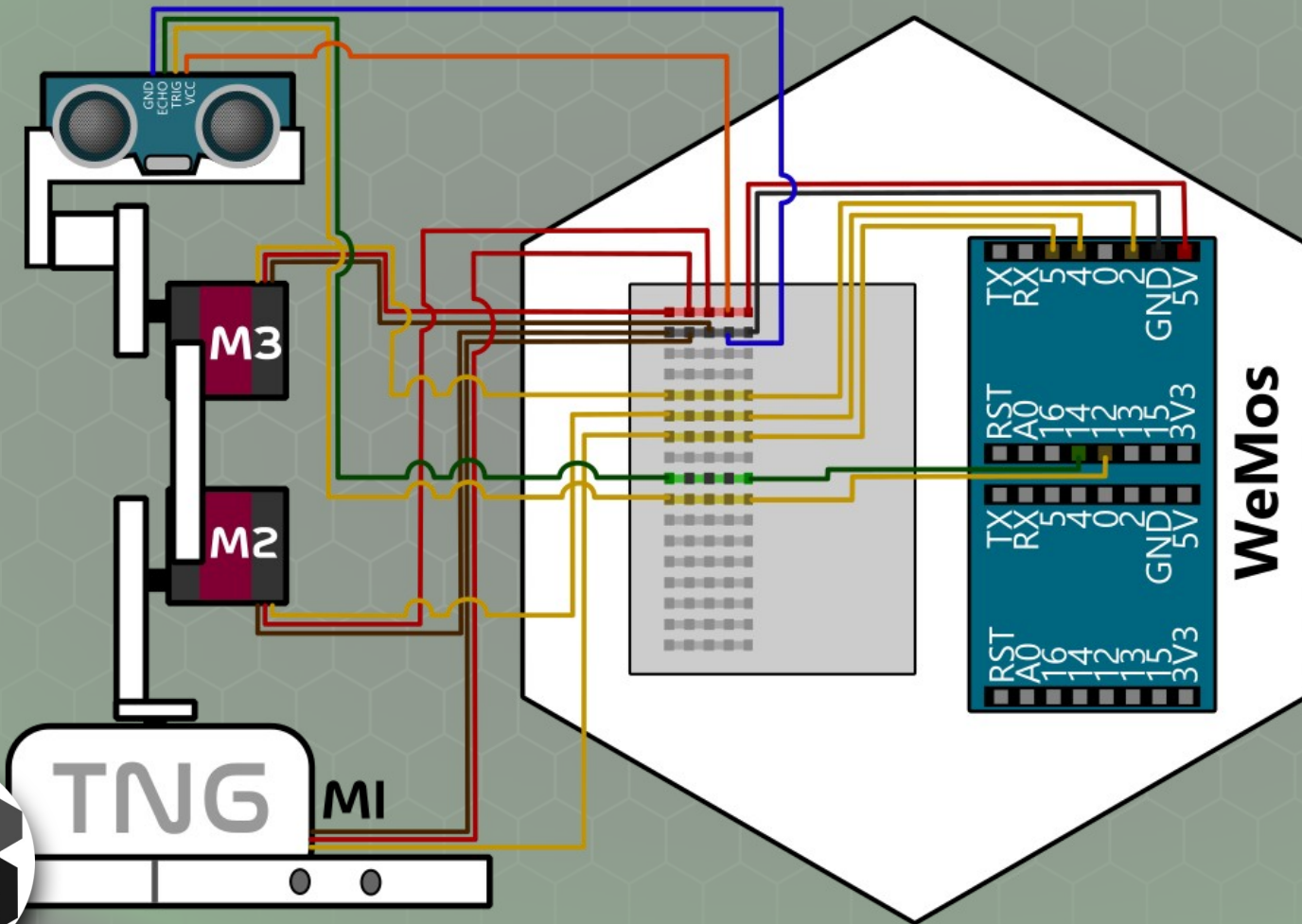

Sensor GND ▶ GND  
Sensor Echo ▶ Pin 14  
Sensor Trig ▶ Pin 12  
Sensor VCC ▶ 5V

M1(**red**) ▶ 5V  
M1(**brown**) ▶ GND  
M1(**orange**) ▶ Pin 5

M2(**red**) ▶ 5V  
M2(**brown**) ▶ GND  
M2(**orange**) ▶ Pin 4

M3(**red**) ▶ 5V  
M3(**brown**) ▶ GND  
M3(**orange**) ▶ Pin 2





# CODING IN PYTHON

## ESSENTIAL CONCEPTS:

- **Loops** (For, While)
- **Conditions** (If, Elif, Else)
- **Read** inputs (e.g. sensors)
- **Write** outputs (e.g. servos)
- **Functions**(inputs)
- **Sleep**(seconds)
- **Plugins and Libraries**

```
Thonny - D:\Desktop\projects\ROBOTNG LABS\Code\micropython\WS1_1_Distance_Sensor_Test.py ...
File Edit View Run Tools Help
WS1_1_Distance_Sensor_Test.py * x
1  # "Distance Sensor" Written in uPyCraft V1.1 for use with WeMos D1 Mini
2  # Prints reading from distance sensor
3  # B. Beck, ROBOTNG LABS
4
5  from machine import Pin
6  from time import sleep
7  from tng_hcsr04 import HCSR04
8
9  sensor = HCSR04(trig_pin=12, echo_pin=14, echo_timeout_us=200000)
10
11 while True:
12     distance = sensor.distance_cm()
13     if distance > 5 and distance < 200:
14         print(distance)
15     sleep(0.1)
```

MicroPython (ESP8266) • COM6



# DON'T PANIC

Python can be used for nearly any project

Same concepts apply in all languages; **syntax** varies

Learning curve flattens quickly!

Start small, work from examples and follow tutorials

```
Thonny - D:\Desktop\projects\ROBOTNG LABS\Code\micropython\WS1_2_Single_Motor_Test.py @ 24 : 9
File Edit View Run Tools Help
WS1_2_Single_Motor_Test.py x
1 #Robo Buddy motor test Written in uPyCraft V1.1 for use with WeMos D1 Mini
2 #B. Beck, ROBOTNG LABS
3
4 #import functions from libraries
5 from machine import Pin,PWM
6 from time import sleep
7
8 #assign pin to servo and initialize servomotor
9 Motor1 = PWM(Pin(5, mode=Pin.OUT))
10 Motor1.freq(50)
11
12 #start servo m1 at center position (in degrees)
13 m1 = 90
14
15 #convert degrees to the corresponding PWM signal number
16 #sets servo to position pos1
17 Motor1.duty(int(0.54*m1 + 25.6))
18 sleep(3)
19
20 m1 = 0
21 Motor1.duty(int(0.54*m1 + 25.6))
22 sleep(3)
23
24 m1 = 180
25 Motor1.duty(int(0.54*m1 + 25.6))
26 sleep(3)
```



# PULSE-WIDTH MODULATION

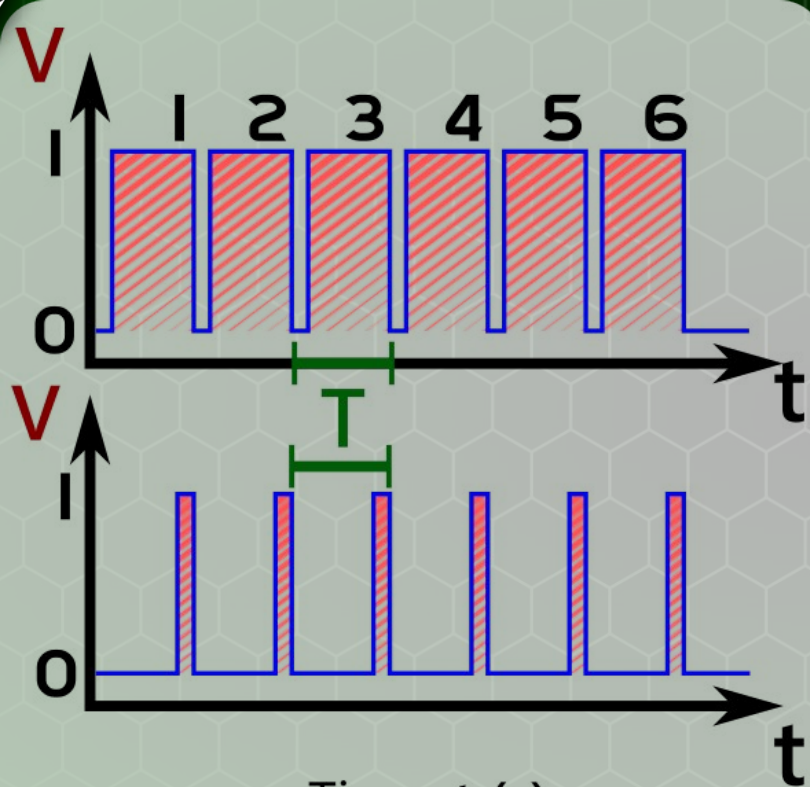

Time:  $t$  (s)  
Period:  $T$  (s)  
Signal Pin:  $V$  (binary)

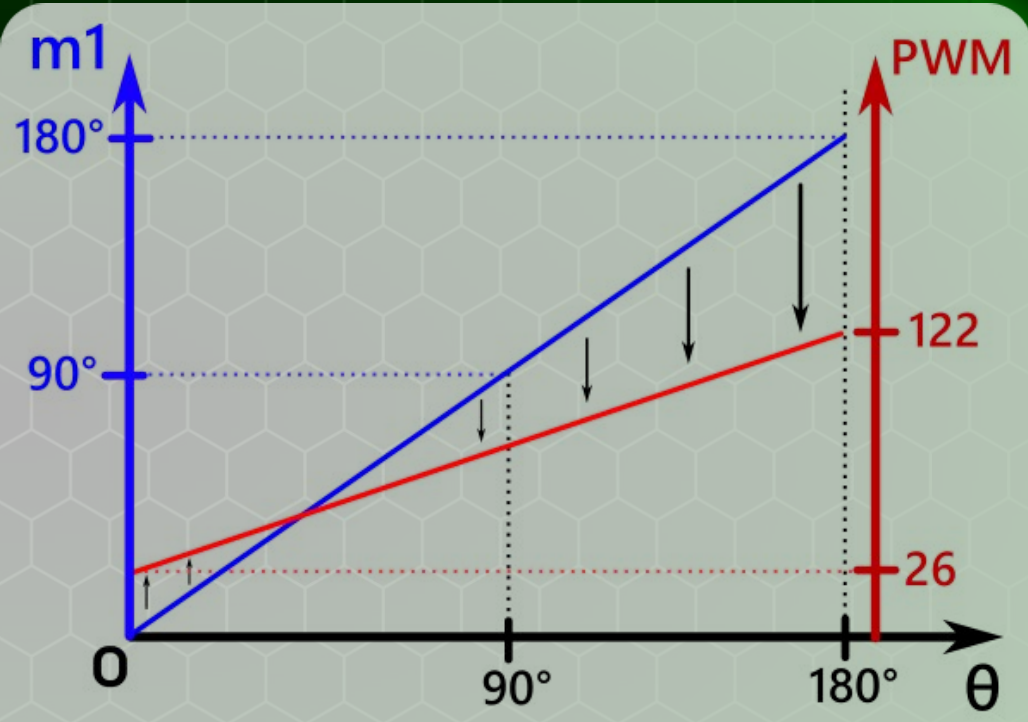

Servo Position:  $\theta$  (degrees)  
Input Angle:  $m1$  (degrees)  
PWM Value:  $PWM$  (integers)



**HAUNTED HEXLAB™**  
**INTERMISSION 1**

HAUNTED HEXLAB™

PART 2:

CREATURE CRAFTING





# HEXLINK + ROBOBUDDY

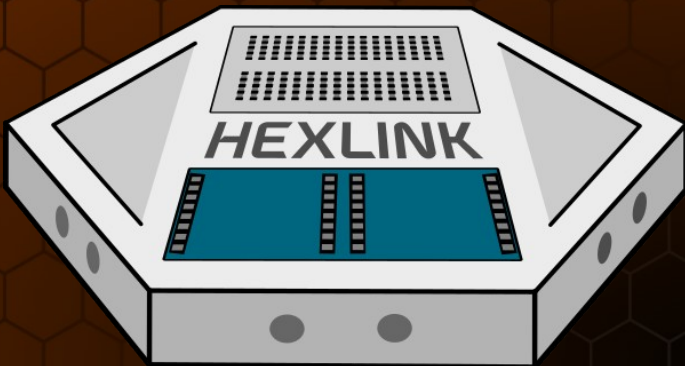

- **WeMos D1 mini microcontroller** and **protoboard** on a 3d-printed hexagonal base.
- Edge magnets connect to robotics activity kits from **ROBOTNG LABS**.
- Code in **Python** using the **Thonny IDE**.
- **No Soldering** required!

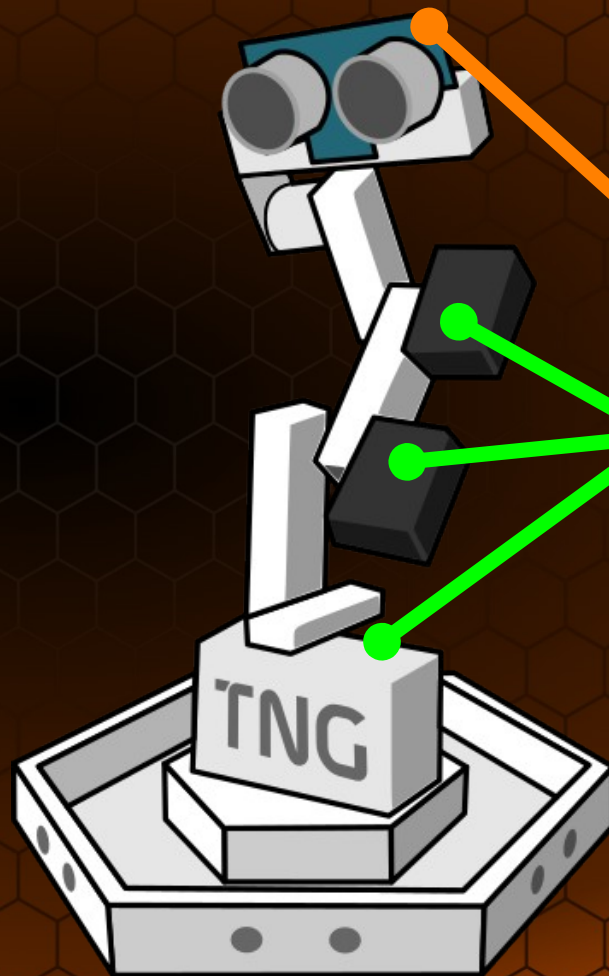

Ultrasonic  
Distance Sensor

3 x ServoMotors  
(180° range)



# DESIGN INSPIRATION

## CRAFT IDEAS

- Paper Masks
- Pipecleaner Wireframes
- Ears, Tails, Dangling Appendages
- Tissue Paper Clothing
- "Famous Robot" Costumes



## CODE IDEAS

- Pre-loaded Examples Available
- Shiver
- Hide & Peek
- Stun and Faint
- Nervous/Paranoid Turning
- Sway to "flap wings"
- Distance Sensor Interactions



# COSTUME CONTEST!

## PEOPLES' CHOICE

Hearts and minds won  
in unexpected, or less  
technical ways



## MOST COMPLEX

The most impressive  
or intricately crafted  
costume!



## BEST CODE

Best use of code to  
bring a costume to  
life!



# CONTEST RULES

## CRAFTING

- Use only the crafting **materials provided**
- **No permanent modifications** to RoboBuddy (please ask if unsure)

## CODING

- Use and edit provided code, or write your own
- We will help implement **your** ideas if we can!

## VOTING

- No voting for your own team
- Vote for each team only once
- In the event of a tie or other confusion, a ROBOTNG LABS panel will decide the victor





# HAUNTED HEXLAB™

## CRAFTING TIME!

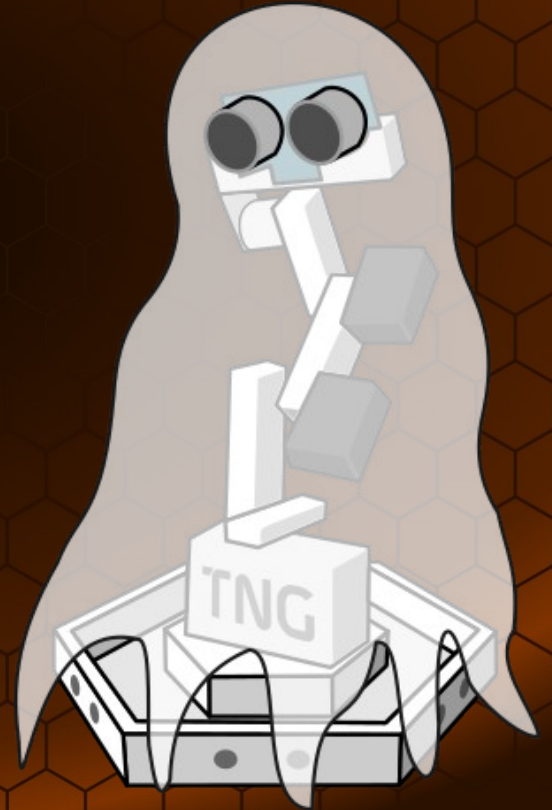



**HAUNTED HEXLAB™**  
**INTERMISSION 2**

A purple bat-like character with large white eyes and wings is perched on a dark grey TNG base. The base has the letters 'TNG' on it.

**HAUNTED HEXLAB™**

**PART 3:**

**PRESENTATIONS, VOTING  
AND CONTEST RESULTS!**



# CONGRATULATIONS!



The most impressive or intricately crafted costume!

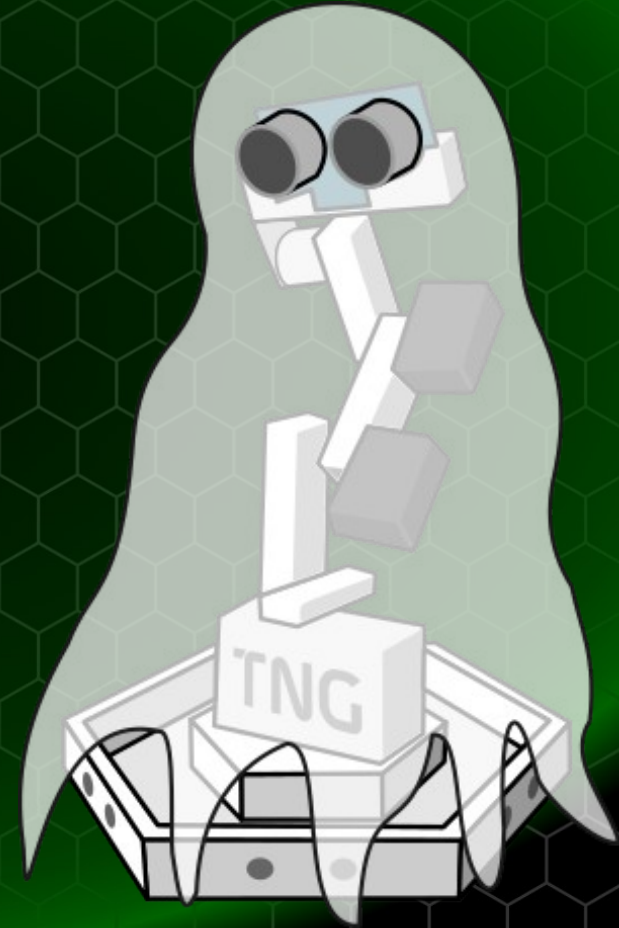

# CONGRATULATIONS!

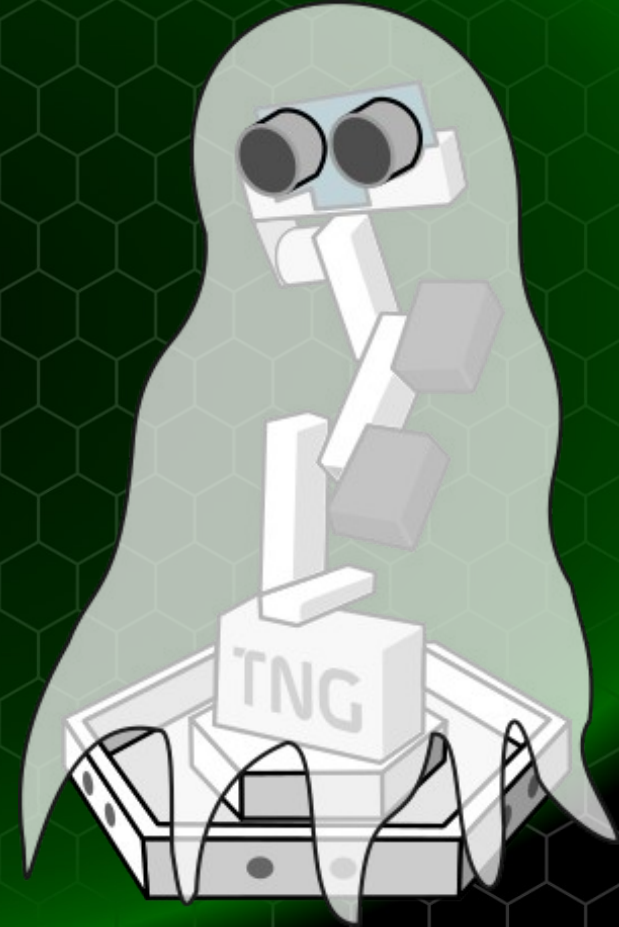

Best use of code to  
bring a costume to life!



# CONGRATULATIONS!



Hearts and minds won in  
less technical ways

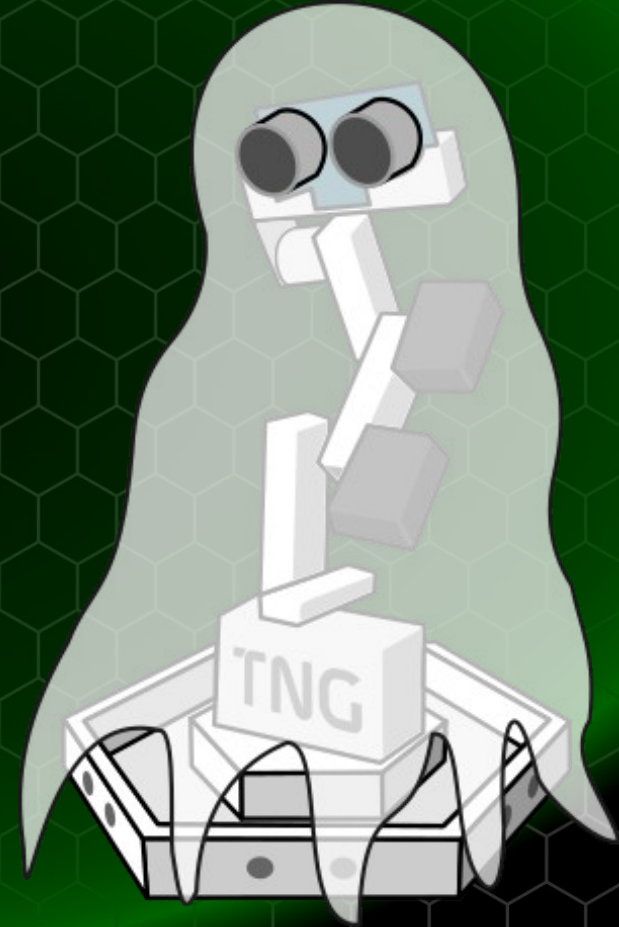



**ROBOTNG LABS**

**THE NEXT GENERATION**

**ROBOTNG.CA**

**HAUNTED HEXLAB™**

**THANK YOU FOR JOINING US**

**STAY CONNECTED WITH ROBOTNG LABS:**

**YouTube:** [ROBOTNG LABS \(youtube.com/robotng\)](https://www.youtube.com/robotng)

**Discord:** [ROBOTNG.CA \(discord.gg/AAC8jbggh3n\)](https://discord.gg/AAC8jbggh3n)

**Instagram:** [instagram.com/robotng.ca](https://www.instagram.com/robotng.ca)

**email:** [robotng.ca@gmail.com](mailto:robotng.ca@gmail.com)